



VFB_YMD-5W Series

WIDE INPUT ISOLATED & REGULATED
5W OUTPUT SINGLE OUTPUT
DIP PACKAGE

RoHS

multi-country patent protection

FEATURES

- Wide (2:1) Input Range
- Efficiency to 85%
- Operating Temperature: -40°C~+71°C
- 1.5KVDC Isolation
- Single Output
- Metal Shielding Package
- No Heat Sink Required
- Industry Standard Pin out
- MTBF>1,000,000 hours
- Short circuit protection
- RoHS Compliance

APPLICATIONS

The VFB_YMD-5W Series are specially designed for applications where a wide range input voltage power supplies are isolated from the input power supply in a distributed power supply system on a circuit board.

These products apply to:

- 1) Where the voltage of the input power supply is wide range (voltage range: 2:1);
- 2) Where isolation is necessary between input and output (Isolation =1500VDC)
- 3) Where the regulation of the output voltage and the output ripple noise are demanded.

PRODUCT PROGRAM

Part Number	Input			Output			Efficiency (% Typ)	Package Style
	Voltage (VDC)			Voltage (VDC)	Current (mA)			
	Nominal	Range	Max*		Max	Min**		
VFB1205YMD-5W	12	9~18VDC	20	5	1000	100	74	DIP
VFB1212YMD-5W	12	9~18VDC	20	12	420	42	77	DIP
VFB1215YMD-5W	12	9~18VDC	20	15	333	34	80	DIP
VFB1224YMD-5W	12	9~18VDC	20	24	208	21	82	DIP
VFB2405YMD-5W	24	18~36VDC	40	5	1000	100	77	DIP
VFB2412YMD-5W	24	18~36VD	40	12	420	42	81	DIP
VFB2415YMD-5W	24	18~36VD	40	15	333	34	84	DIP
VFB2424YMD-5W	24	18~36VD	40	24	208	21	85	DIP
VFB4805YMD-5W	48	36~72VDC	80	5	1000	100	79	DIP
VFB4812YMD-5W	48	36~72VD	80	12	420	42	85	DIP
VFB4815YMD-5W	48	36~72VD	80	15	333	34	85	DIP
VFB4824YMD-5W	48	36~72VD	80	24	208	21	86	DIP

* Input voltage above it may cause permanent damage to the device.

** The load shouldn't be less than 10%,otherwise ripple will increase dramatically.

MODEL SELECTION

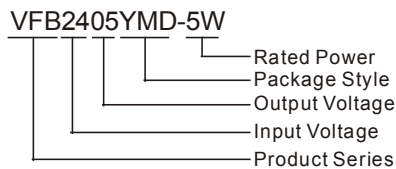

ISOLATION SPECIFICATIONS

Item	Test conditions	Min	Typ	Max	Units
Isolation voltage	Flash tested for 60 seconds	1500			VDC
Isolation resistance	Test at 500VDC	1000			MΩ

OUTPUT SPECIFICATIONS

Item	Test conditions	Min	Typ	Max	Units
5W output power	See below products program	0.5		5	W
Positive Voltage accuracy	Refer to recommended circuit		±1	±3	%
Load regulation	From 10% to 100% load		±0.5	±1	
Line regulation	Input voltage from low to high		±0.2	±0.5	
Temperature drift (Vout)	Refer to recommended circuit			0.03	%/°C
Ripple	20Hz-300KHz bandwidth		30	50	mVp-p
Noise	DC-20MHz bandwidth		80	150	p
Switching frequency	100% load, nominal input voltage		300		KHz

Note:

- 1.All specifications measured at T_a=25°C, humidity<75%, nominal input voltage and rated output load unless otherwise specified.
- 2.See below recommended circuits for more details.



MORNSUN Science & Technology Ltd.

Address: 8th floor 8th building, Huangzhou Industrial District, Guangzhou, China
Tel: 86-20-38601850
Fax: 86-20-38601272
Http://www.mornsun-power.com

COMMON SPECIFICATION

Output Short Circuit Protection	Continuous
Temperature Rise at Full Load	30°C (TYP)
Cooling	Free Air Convection
No-load Power Consumption	300mW (typical)
Operating Temperature Range	-40°C~+85°C
Storage Temperature Range	-55°C ~+125°C
Lead Temperature***	300°C (1.5mm from case for 10 seconds)
Storage Humidity Range	≤ 95%
Case Material	Metal
MTBF	>1,000,000 hours

***Lead Temperature 1.5mm from case for 10 seconds.

TYPICAL CHARACTERISTICS

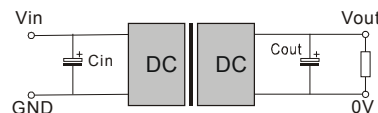
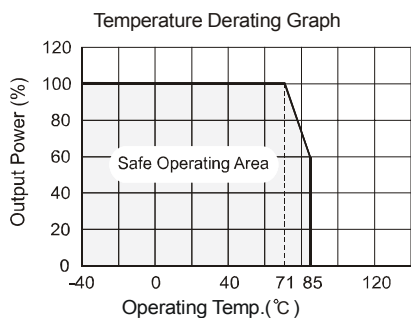

(Figure 1)

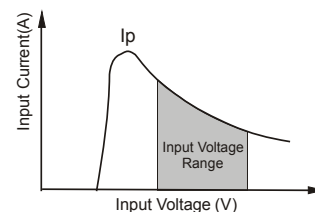

(Figure 2)

and the rippled voltage do not exceed the module standard. Input current of power supply should afford the startup current of this kind of DC/DC converter. (See figure 2)

Requirement on Output Load

To ensure this module operate efficiently and reliably, a minimum load is specified for this kind of DC/DC converter in addition to a maximum load (namely full load). During operation, make sure the specified range of input voltage is not exceeded, the minimum output load is not less than **10%** of the full load, and that this product **should never be operated under no load!!!** If the actual load is less than the specified minimum load, the output ripple of this type of DC/DC converter will increase drastically and at the same time efficiency & reliability of the circuit will decrease deeply. If the actual output power from the load in your circuit is very small, please connect a resistor with proper resistance at the output end to in parallel to increase the load, or use our company's other products with a lower rated output power.

FOOTPRINT DETAILS

Pin	Function
1	GND
2	Vin
3	+Vo
4	OV

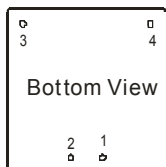

OUTLINE DIMENSIONS & RECOMMENDED FOOTPRINT

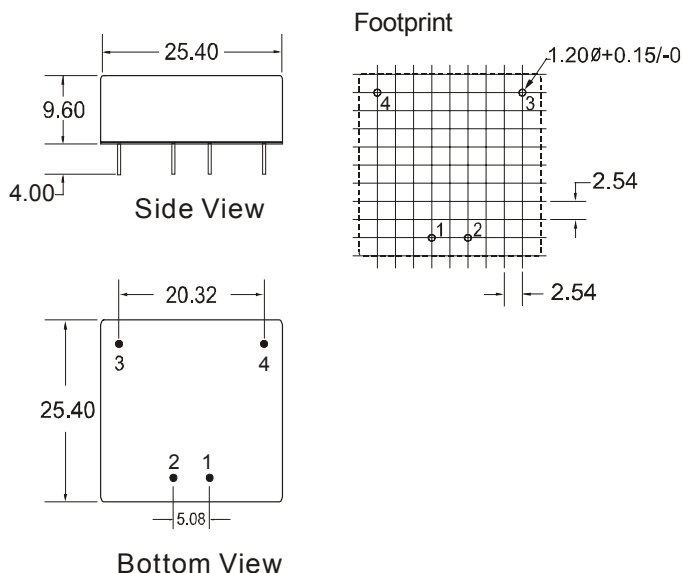

Note: All Pins on a 2.54mm pitch; All Pin diameters are 1.00 mm (Tolerance: + 0.25); All dimensions in mm.

APPLICATION NOTE

Recommended Circuit

All the VRB_D-5W Series have been tested according to the following recommended testing circuit before leaving factory. This series should be tested under load. Never be tested under no load (See Figure 1 & 2). If you want to further decrease the input/output ripple, you can increase capacitance properly or choose capacitors with low ESR. However, the capacitance should not be too high. (See table 1). If you want to use the products in high EMI, please choose our metal packaged products.

Input Current

When it is used in unregulated power supply, be sure that the fluctuating range of the power supply



MORNSUN Science & Technology Ltd.

Address: 8th Floor 8th Building, Huangzhou Industrial District, Guangzhou, China
Tel :86-20-38601850
Fax:86-20-38601272
Http:// www.mornsun-power.com