

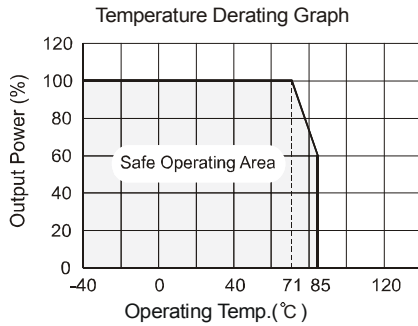

## COMMON SPECIFICATION

Output Short Circuit Protection	Continuous 1 hour
Temperature Rise at Full Load	40°C (TYP)
Cooling	Free Air Convection
Operating Temperature Range	-40°C~+85°C
Storage Temperature Range	-55°C ~+125°C
Lead Temperature***	300°C (1.5mm from case for 10 seconds)
Storage Humidity Range	≤ 95%
Case Material	Metal
MTBF	>1,000,000 hours
***Lead Temperature 1.5mm from case for 10 seconds.	

## TYPICAL CHARECTERISTICS



## FOOTPRINT DETAILS

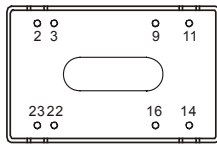

Bottom View

Pin	Function
2,3	GND
9	NO Pin
11	NC
14	+Vo
16	0V
22,23	Vin

## OUTLINE DIMENSIONS & RECOMMENDED FOOTPRINT

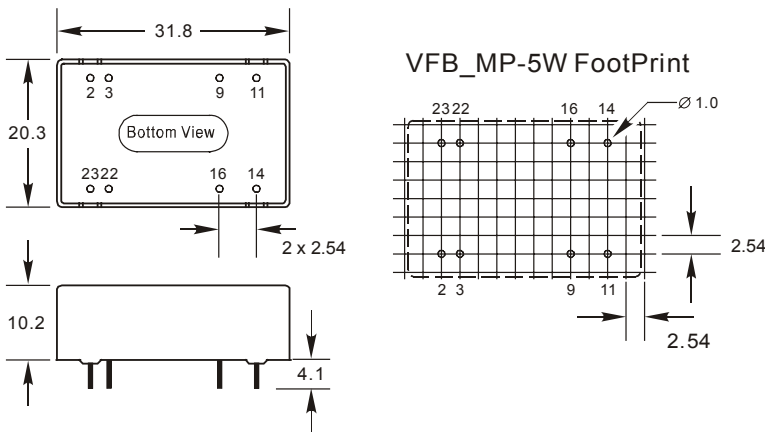

Note: All Pins on a 2.54mm pitch; All Pin diameters are 0.50 mm(Tolerance:±0.10); All dimensions in mm.

## APPLICATION NOTE

### Recommended Circuit

All the VFB\_MP-5W Series have been tested according to the following recommended testing circuit before leaving factory. This series should be tested under load. Never be tested under no load (See Figure 1 & 2). If you want to further decrease the input/output ripple, you can increase capacitance properly or choose capacitors with low ESR. However, the capacitance should not be too high.(See table 1).

### Input Current

When it is used in unregulated power supply, be sure that the fluctuating range of the power supply and the rippled voltage do not exceed the module standard. Input current of power supply should afford the startup current of this kind of DC/DC module. (See figure 2)

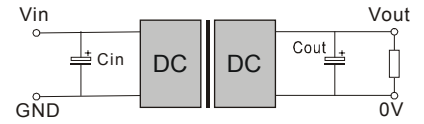

(Figure 1)

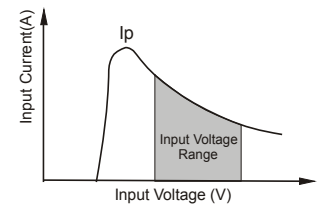

(Figure 2)

### External Capacitor

Although this series of DC/DC converter can work without external capacitor, in order to keep an optimum performance, however, it needs external capacitor. (See Table 1)

**The products cannot be used in parallel and in hot plug.**

### External Capacitor Table(See Table 1)

Vin	Cin	Vout	Cout
12V	100uF	5V	100uF each 1A Current
24V	100uF	12V	
48V	100uF	15V	
		24V	



**MORNSUN Science & Technology Ltd.**

Address: 8th Floor 8th Building, Huangzhou Industrial District, Guangzhou, China  
Tel :86-20-38601850  
Fax:86-20-38601272  
Http:// www.mornsun-power.com