

280W Parallel switching power supply



- AC input range selected by switch
- Protections: Short circuit/Over load/Over voltage
- Forced air cooling by built-in DC ball bearing fan
- Built-in constant current limiting circuit
- Built-in cooling Fan ON-OFF control
- Built-parallel function
- Built-in active current sharing
- LED indicator for power on
- Fixed switching frequency at 25KHz
- 2 years warranty



SPECIFICATION

MODEL		PS-280-13.5	PS-280-27
OUTPUT	DC VOLTAGE	13.5V	27V
	RATED CURRENT	20A	10A
	CURRENT RANGE	0 ~ 20A	0 ~ 10A
	RATED POWER	270W	270W
	RIPPLE & NOISE (max.) Note.3	150mVp-p	150mVp-p
	VOLTAGE ADJ. RANGE	12 ~ 15V	24 ~ 30V
	VOLTAGE TOLERANCE Note.2	±1.0%	±1.0%
	LINE REGULATION	±0.5%	±0.5%
	LOAD REGULATION	±0.5%	±0.5%
SETUP, RISE, HOLD TIME		200ms, 50ms, 10ms	
INPUT	VOLTAGE RANGE	90 ~ 132VAC / 180~264VAC By switching 254 ~ 370VDC	
	FREQUENCY RANGE	47 ~ 63Hz	
	EFFICIENCY(Typ.)	80%	82%
	AC CURRENT	5.5A/115VAC 3A/230VAC	
	INRUSH CURRENT(max.)	COLD START 35A	
	LEAKAGE CURRENT	<1mA / 240VAC	
PROTECTION	OVER LOAD	105 ~ 135% of rate load Protection type : Fold back current limiting, recovers automatically after fault condition is removed.	
	OVER VOLTAGE	15.53 ~ 18.23V	31.05 ~ 36.45V Protection type : Constant voltage limiting, recovers automatically after fault condition is removed.
FUNCTION	FAN CONTROL, O.T.P.	RTH3 ≥ 60°C FAN ON, ≤ 50°C FAN OFF, ≥ 90°C output shutdown	
ENVIRONMENT	WORKING TEMP., HUMIDITY	-10 ~ +60°C (Refer to output load derating curve), 20 ~ 90% RH	
	STORAGE TEMP., HUMIDITY	-20 ~ +85°C, 10 ~ 95% RH	
	TEMP. COEFFICIENT	±0.03%/°C (0 ~ 50°C)	
	VIBRATION	10 ~ 500Hz, 2G 10min./1cycle, period for 60min. each along X, Y, Z axes	
SAFETY & EMC	SAFETY STANDARDS	UL1012 Approved	
	EMI CONDUCTION & RADIATION	Design refer to FCC Part15 J Conduction Class B	
	WITHSTAND VOLTAGE	I/P-O/P:1.5KVAC I/P-FG:1.5KVAC O/P-FG:0.5KVAC	
	ISOLATION RESISTANCE	I/P-O/P, I/P-FG, O/P-FG:100M Ohms/500VDC	
OTHERS	MTBF	209.4K hrs min. MIL-HDBK-217F (25°C)	
	DIMENSION	150*140*86mm (L*W*H)	
	PACKING	1.43Kgs/pcs, 8pcs/11.44Kgs/0.97CUFT	
NOTE	<p>1. All parameters NOT specially mentioned are measured at 230VAC input, rated load and 25°C of ambient temperature.</p> <p>2. Ripple & noise are measured at 20MHz of bandwidth by using a 12" twisted pair-wire terminated with a 0.1uf & 47uf parallel capacitor.</p> <p>3. Tolerance : includes set up tolerance, line regulation and load regulation.</p>		

Mechanical Specification

Case No. 907 Unit:mm

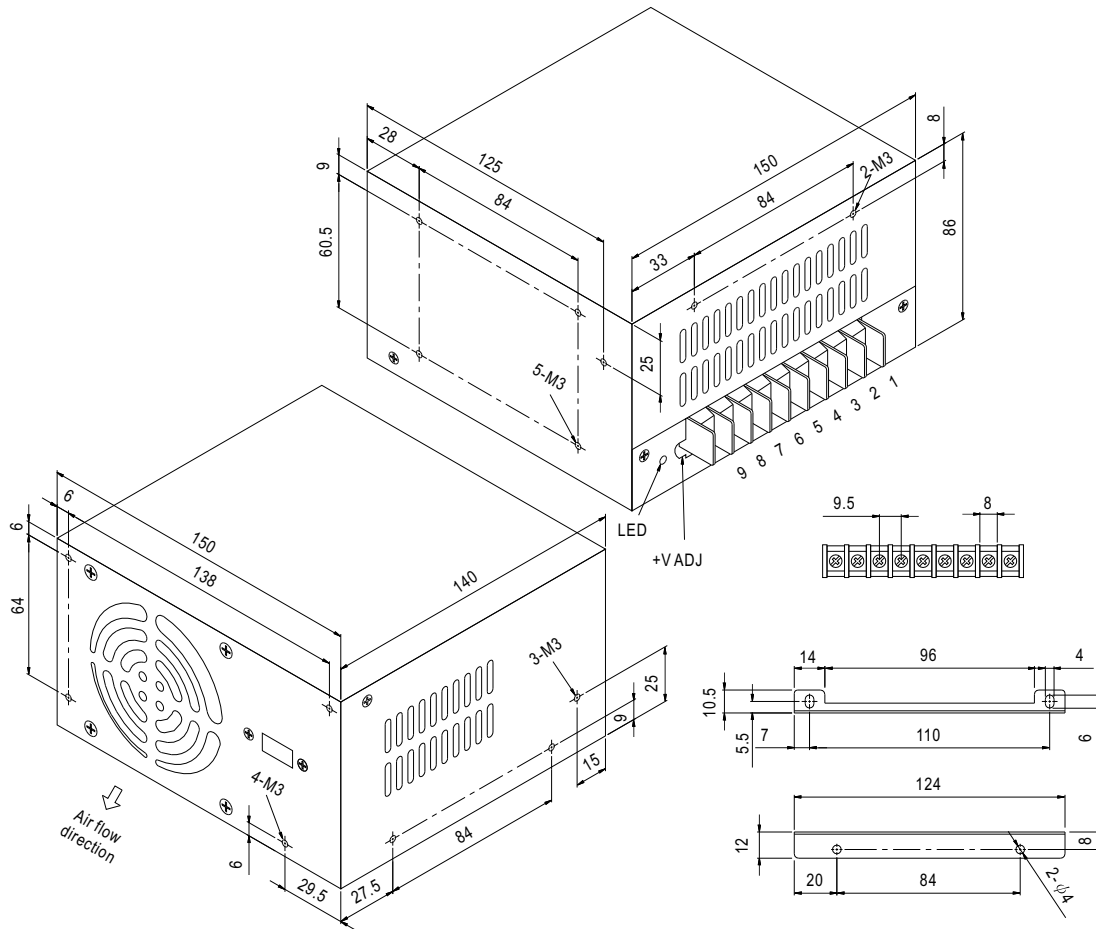

Terminal Pin. No Assignment

Pin No.	Assignment	Pin No.	Assignment	Pin No.	Assignment
1	AC/L	4	NC	8,9	DC OUTPUT +V
2	AC/N	5	P		
3	FG \perp	6,7	DC OUTPUT -V		

Output Derating

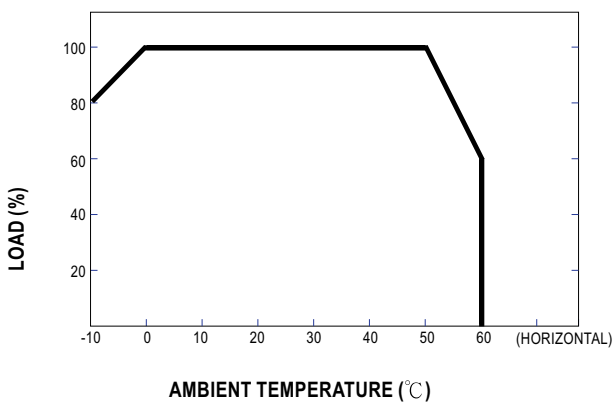

Static Characteristics (13.5V)

