

EC3CB

15 WATT WIDE INPUT DC-DC CONVERTERS



Features

- 15W Isolated Output
- 2:1 Input Range
- Efficiency to 82%
- Six-Sided Shield
- 200KHz Switching Frequency
- Regulated Outputs
- Pi Input Filter
- Continuous Short Circuit Protection
- Meets EN55022 Class B, Conducted

MODEL NUMBER	INPUT VOLTAGE	OUTPUT VOLTAGE	OUTPUT CURRENT	INPUT CURRENT		% EFF.	CASE
				NO LOAD	FULL LOAD		
EC3CB01		5 VDC	3000 mA	30 mA	1660 mA	75	
EC3CB02		12 VDC	1250 mA	30 mA	1625 mA	78	
EC3CB03		15 VDC	1000 mA	30 mA	1625 mA	78	
EC3CB04	9-18 VDC	±12 VDC	±625 mA	35 mA	1620 mA	77	C/S
EC3CB05		±15 VDC	±500 mA	35 mA	1620 mA	77	
EC3CB06		±5 VDC	±1500 mA	35 mA	1620 mA	77	
EC3CB07		3.3 VDC	3000 mA	30 mA	1178 mA	70	
EC3CB11		5 VDC	3000 mA	15 mA	812 mA	78	
EC3CB12		12 VDC	1250 mA	20 mA	772 mA	81	
EC3CB13		15 VDC	1000 mA	20 mA	772 mA	81	
EC3CB14	18-36 VDC	±12 VDC	±625 mA	25 mA	780 mA	80	C/S
EC3CB15		±15 VDC	±500 mA	25 mA	780 mA	80	
EC3CB16		±5 VDC	±1500 mA	25 mA	780 mA	80	
EC3CB17		3.3 VDC	3000 mA	15 mA	557 mA	74	
EC3CB21		5 VDC	3000 mA	10 mA	390 mA	80	
EC3CB22		12 VDC	1250 mA	15 mA	381 mA	82	
EC3CB23		15 VDC	1000 mA	15 mA	381 mA	82	
EC3CB24	36-72 VDC	±12 VDC	±625 mA	20 mA	386 mA	81	C/S
EC3CB25		±15 VDC	±500 mA	20 mA	386 mA	81	
EC3CB26		±5 VDC	±1500 mA	20 mA	386 mA	81	
EC3CB27		3.3 VDC	3000 mA	20 mA	271 mA	76	

NOTE: 1. Nominal Input Voltage 12, 24 or 48 VDC
2. Alternative pin-out version. To order, suffix a "S" to the standard model number.

Specifications

INPUT SPECIFICATIONS:

Input Voltage Range.....	12V	9-18V
	24V	18-36V
	48V	36-72V
Input Filter.....		Pi Type

OUTPUT SPECIFICATIONS:

Voltage Accuracy		
Single Output.....		±1.0% max.
Dual + Output.....		±1.0% max.
Dual - Output.....		±3.0% max.
Voltage Balance Dual Output at Full Load.....		±1.0% max.
Transient Response		
Single 25% Step Load Change.....		<500µ sec.
Dual FL,1/2L ±1% Error Band.....		<500µ sec.
Ripple & Noise 20MHz BW.....		10mV RMS max. 75mV p-p max.
Temperature Coefficient.....		±0.02%/°C
Short Circuit Protection.....		Indefinite & Current Limit
Line Regulation ¹ Single/Dual Output.....		±0.2% max.
Load Regulation ² Single/Dual Output.....		±1.0% max.

GENERAL SPECIFICATIONS:

Efficiency.....		See Table
Isolation Voltage.....		500 VDC min.
Isolation Resistance.....		10 ⁹ ohms
Switching Frequency.....		200KHz, typ.
Operating Temperature Range.....		-25°C to + 71°C
Case Temperature.....		100°C max.
Cooling.....		Free-Air Convection
Storage Temperature Range.....		-40°C to + 100°C
EMI/RFI.....		Conductive EMI Meet EN55022 Class B
Dimensions.....		2 x 2 x 0.4 inches (50.8 x 50.8 x 10.2mm)

Case Material..... Black Coated Copper With Non-Conductive Base

NOTE:

1. Measured From High Line to Low Line
2. Measured From Full Load to 1/4 Full load
3. Determine the Correct Fuse Size by Calculating the Maximum DC Current Drain at Low Line Input, Maximum Load and Then Adding 20 to 25% to Get Desired Fuse Size.
4. Alternative Pin Configuration Suffix "S"

CASE C

All Dimensions In Inches(mm)
Tolerance .xx= ±.04, .xxx= ±.010

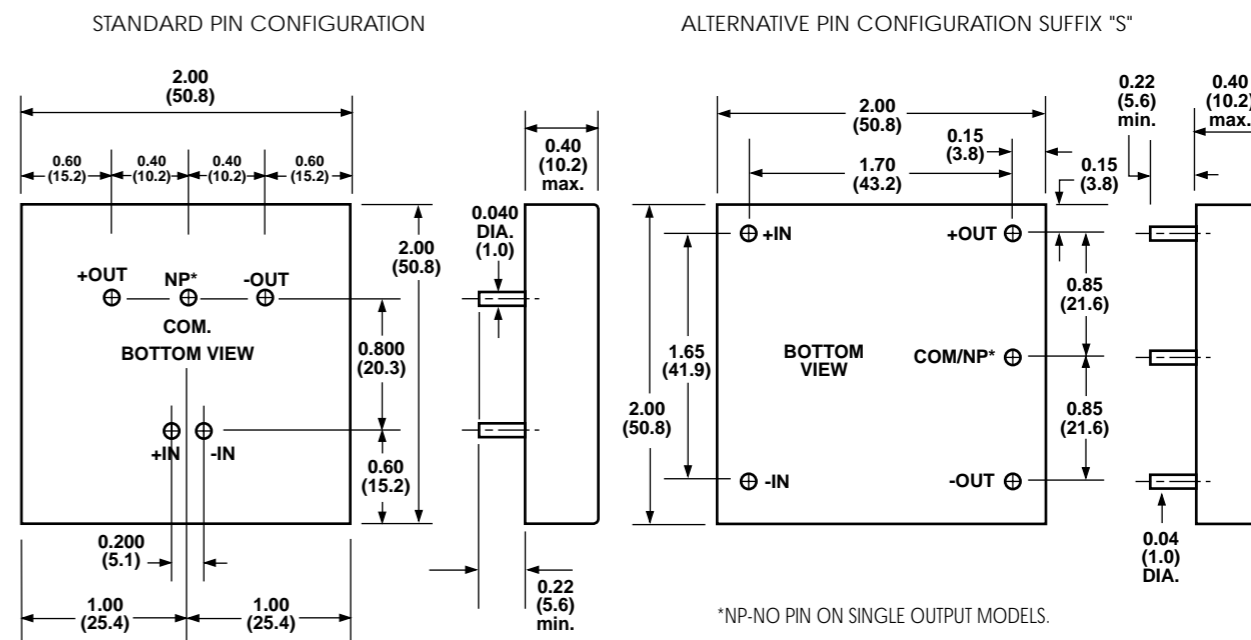

*NP-NO PIN ON SINGLE OUTPUT MODELS.