

Application Note

Derating

The operating case temperature range of the CHB75 Dual series is -40°C to +100°C. When operating the CHB75 Dual, proper derating or cooling is needed.

Following is the derating curve of CHB75 Dual without heat sink

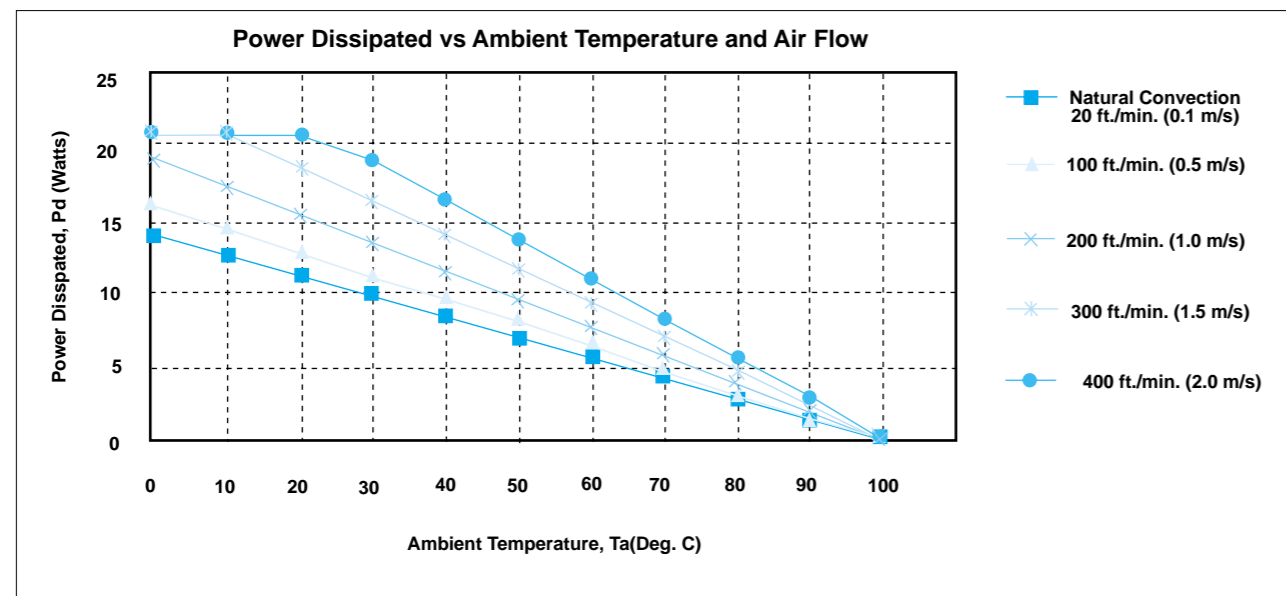

Forced Convection Power Derating with No Heat Sink

Where:

The power dissipation (Pd):

$$Pd = Pi - Po = Po (1 - \eta) / \eta$$

The thermal resistance are list below:

Chart of Thermal Resistance vs Air Flow:

AIR FLOW RATE	TYPICAL Rca
Natural Convection	7.12 °C/W
100 ft./min.	6.21 °C/W
200 ft./min.	5.17 °C/W
300 ft./min.	4.29 °C/W
400 ft./min.	3.64 °C/W

The temperature rise (ΔT):

$$\Delta T = Pd * Rca$$

Remote ON/OFF Control

The CHB75 Dual series allows the user to switch the module on and off electronically with remote on/off feature. The CHB75 Dual series are available with "positive logic" or "negative logic" (option).

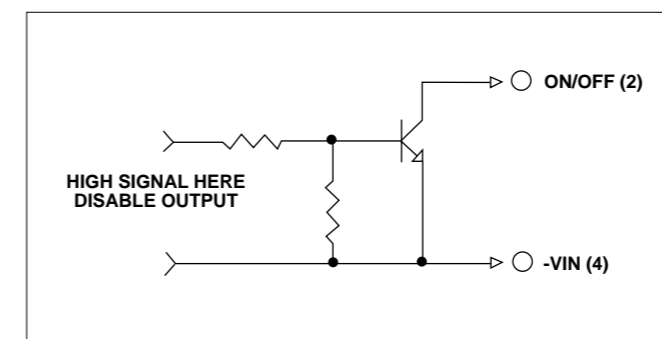

Logic Table

Logic State (PIN 2)	Negative Logic	Positive Logic
Logic Low - Switch Closed	Module on	Module off
Logic High - Switch Open	Module off	Module on

External Output Trimming

Output may optionally be externally trimmed ($\pm 5\%$) with a fixed resistor or an external trimpot as shown.

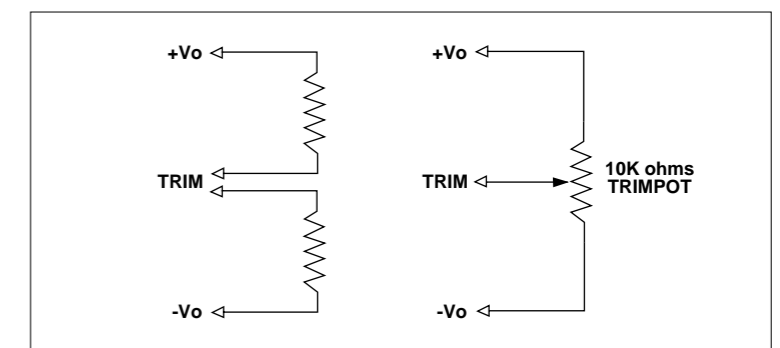

Output Noise

The output noise is measured with 10 μ F tantalum capacitor and 1.0 μ F ceramic capacitor across output.

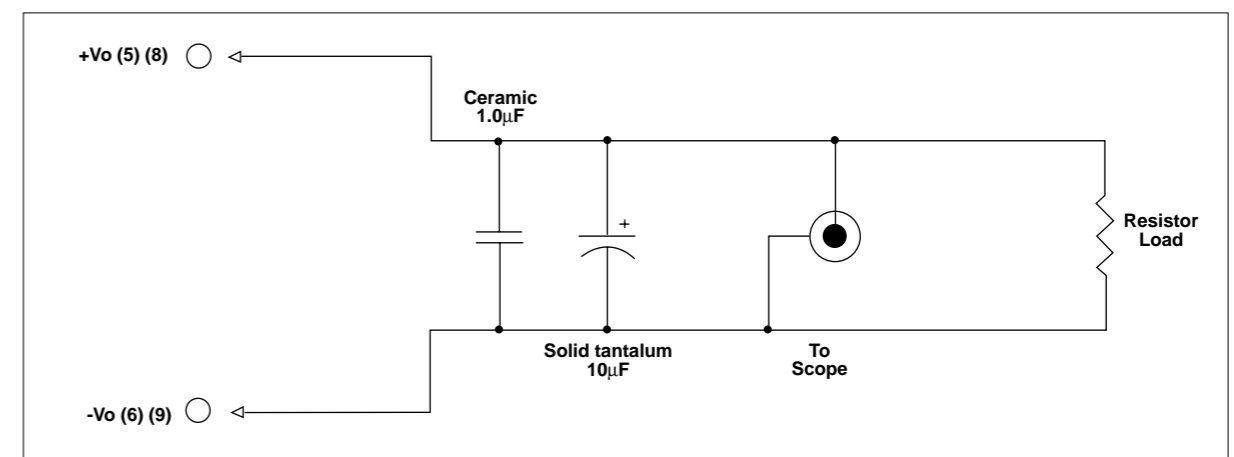

Output Noise Test Circuit schematic