

PROVISIONAL SPECIFICATION

The APC-D2000 series realises a single high power modular solution for bulk DC requirements in a 2U x 3U unit. Utilising up to 4 of the market leading APC500 series DC:DC Converters, the APC-D2000 provides one of the most cost-effective and flexible solutions to integrate new and legacy power systems with its added ability to supply **STEP-UP** conversion from 24VDC or 28VDC input to 48VDC output.

Each unit provides up to 2,000W each, and when 4 units are mounted vertically gives a massive 8,000W per 3U high 19" rack, or 6,000W of N+1 redundancy. For low profile requirements, the units can be mounted in a 2U 19" rack and offer a high density 6,000W per rack or 4,000W of N+1 redundancy

Ideal for applications where maximum flexibility for a scalable and cost-effective bulk DC power solution with precisely regulated DC output is required.



DC FEATURES

- ❑ Very flexible modular system
- ❑ Step-Up conversion 24 up to 48
- ❑ Up to 8,000W Total Power.
- ❑ 3 modules in 2U 19-inch Rack or 4 modules in 3U 19-inch Rack
- ❑ Integral Oring Diodes
- ❑ Wide range of DC output Voltages 24VDC, 28VDC or 48VDC
- ❑ ±10% Output Adjustment Range
- ❑ Hot Plug Capability
- ❑ Active Load Sharing
- ❑ Temperature monitor indication
- ❑ Remote Sensing
- ❑ Overvoltage Protection
- ❑ Group Output Voltage Adjustment
- ❑ Cost Effective Custom Designs
- ❑ Class B EMI filter

Safety Certifications

EN60950



TWO-YEAR WARRANTY

PROVISIONAL SPECIFICATION

APC-D2000 Series - DC Bulk Power System - DC Input-Output 2U x 3U up to 8000W

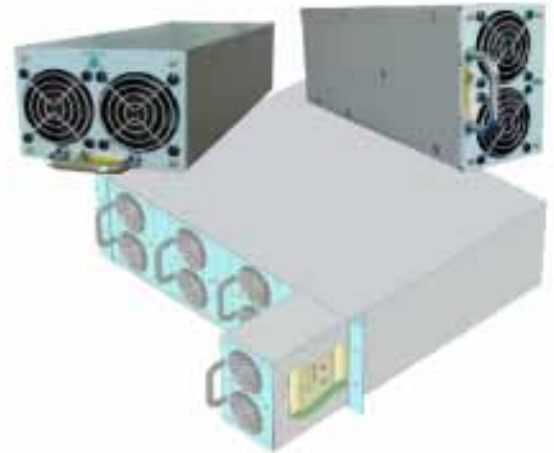
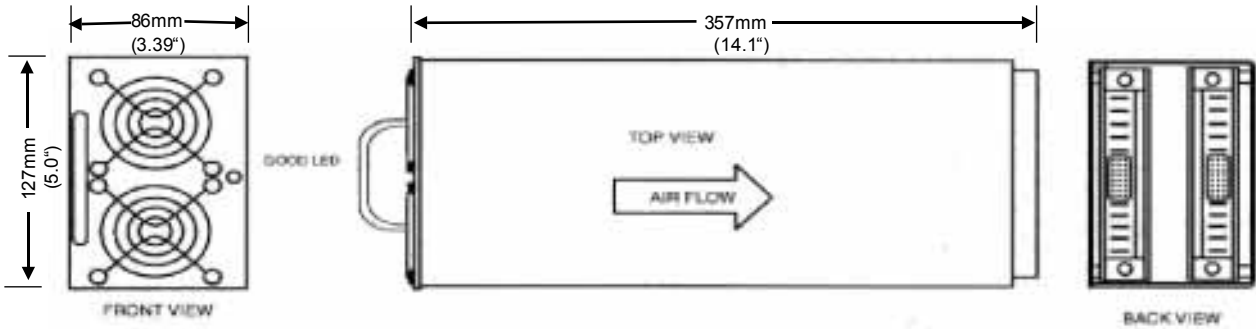

POWER UNIT DETAILS

INPUT SPECIFICATIONS

Input DC Voltage Range.....18V to 36V⁶
36V to 75V
 Maximum Input Protection, Internal fuse.....4 x 40A
 Input Current, Full load104A
 Input EMI Filter, ConductedEN55022 Curve B
 Typical at Nominal Line, Full load and 25°C unless
 otherwise stated

OUTPUT SPECIFICATIONS

Total Output Power,
 Max.....2000W
 Output Voltage(s).....24V, 28V & 48V⁶
 Output Current (@48V).....41.67A
 Voltage Adjustment Range,.....±10.0%
 Total Regulation¹.....±1.0%
 Ripple and noise,Pk-Pk²500mV, 48V Models
 Dynamic Response³.....1ms
 Temperature Coefficient.....0.05%/°C
 Minimum Load0A
 Overload Protection.....Constant Current Limiting
 Overvoltage Protection.....Latched Shutdown/Reset
 Active Current Share⁴.....10% Differential from
 Rated Current
 Remote Sense.....Up to 1V per wire
 Efficiency>85% at Full Load
 Sync Control range320-360kHz, Nominal 330kHz

GENERAL SPECIFICATIONS

Switching Frequency, DC-DC Converter....150kHz Nom.
 Over Temperature Shutdown.....Auto Recovery
 Isolation, class 1.....2000VAC Input - Output
 1500VAC⁵ Input – Ground
 500VAC⁵ Output to Ground

STATUS INDICATORS

Power Good.....Logic Low Output
 Thermal Alarm.....Logic Low Output

ENVIRONMENTAL SPECIFICATIONS

Operating Temperature.....0°C to 70°C Ambient
 Derating1.0%/°C, 50°C to 70°C
 Storage temperature-40°C to 85°C
 Cooling.....Internal DC Ball-Bearing Fans

PHYSICAL SPECIFICATIONS

Case Material,Aluminum
 Dimensions..... See drawing above
 Weight2.8kg (6.16lbs)

Notes

1. At Remote sense point over full line load range and 0 – 100% load change.
2. 20MHz bandwidth. Measured with 0.1uF ceramic and 10uF tantalum capacitors in parallel across the output.
3. 5% deviation recovering to within 1% for 50% load change.
4. Using single wire current share with remote sense connected.
5. Chassis link removed, EMC components disconnected.
6. Ask factory for de-rating at low voltages

Advanced Power Conversion PLC

Unit B5, Armstrong Mall, Southwood Summit Centre, Farnborough, Hants. GU14 0NR England
 Tele: +44 (0) 1252 407800 Fax: +44 (0) 1252 407810
 E-mail: sales@apcuk.com http://www.apcuk.com



July 2003