

Advanced Monolithic Systems

AMS285/AMS385

ADJUSTABLE MICROPOWER VOLTAGE REFERENCE DIODE

FEATURES

- Adjustable from 1.24V to 5.30V
- Operating Current 10 μ A to 20mA
- 1% and 2% Initial Tolerance
- 1 Ω Dynamic Impedance
- Low Temperature Coefficient
- 1.2V Device and 2.5V Device also available
AMS285-1.2 and AMS285-2.5 series, respectively
AMS385-1.2 and AMS385-2.5 series.

APPLICATIONS

- Battery Powered Systems
- Instrumentation
- A/D, D/A Converters
- Temperature measurement
- Current sources
- Notebook/Personal Computer
- Monitors/ VCR/ TV
- Pagers

GENERAL DESCRIPTION

The AMS285/AMS385 are three-terminal micropower band-gap voltage reference diodes. They feature a very low dynamic impedance and good temperature coefficient, operating from 1.24V to 5.3V and over a 10 μ A to 20mA current range. On-chip trimming is used to provide tight voltage tolerance. Since the AMS285/AMS385 is a band-gap reference, uses only transistors and resistors, low noise and good long-term stability result. Careful design of the AMS285/AMS385 has made the device exceptionally tolerant of capacitive loading, making it easy to use in almost any reference application. The wide dynamic operating range allows its use with widely varying supplies with excellent regulation. The extremely low power drain of the AMS285/AMS385 makes these reference diodes useful for micropower circuitry. These voltage references can be used to make portable meters, regulators or general purpose analog circuitry with battery life approaching shelf life. Further more, the wide operating current allows it to replace older references with a tight tolerance part.

The AMS285 is operational in the full industrial temperature range of -40°C to 85°C while AMS385 is operating over a 0°C to 70°C temperature range. The AMS285/AMS385 are available in TO-92, SO-8 and SOT-89 packages.

ORDERING INFORMATION:

TOL.	PACKAGE TYPE			OPERATING TEMPERATURE RANGE
	TO-92	8 LEAD SOIC	SOT-89	
±12mV	AMS285AN	AMS285AS	AMS285AL	-40 to 85° C
±25mV	AMS285BN	AMS285BS	AMS285BL	-40 to 85° C
±25mV	AMS285CN	AMS285CS	AMS285CL	-40 to 85° C
±12mV	AMS385AN	AMS385AS	AMS385AL	0 to 70° C
±25mV	AMS385BN	AMS385BS	AMS385BL	0 to 70° C
±25mV	AMS385CN	AMS385CS	AMS385CL	0 to 70° C

AMS285/AMS385

ABSOLUTE MAXIMUM RATINGS

Reverse Current	30mA	Storage temperature	-55°C to +150°C
Forward Current	10mA	Soldering information	
Operating Temperature Range		TO-92 package: 10 sec.	260°C
AMS285	-40°C to 85°C	SOIC package: Vapor phase (60 sec)	215°C
AMS385	0°C to 70°C	Infrared (15 sec.)	220°C
		SOT-89 package: 10 sec.	265°C

ELECTRICAL CHARACTERISTICS

Electrical Characteristics at $I_R = 100 \mu A$, and $T_A = +25^\circ C$ unless otherwise specified.

Parameter	Conditions	AMS285A			AMS285B			AMS285C			Units
		Min	Typ	Max	Min	Typ	Max	Min	Typ	Max	
Reference Voltage	$I_R = 100 \mu A$	1.228	1.240	1.252	1.215	1.240	1.265	1.215	1.240	1.265	V
Dynamic Output Impedance	$I_{AC} = 0.1I_R$, $f = 20Hz$ $V_{OUT} = V_{REF}$ $V_{OUT} = 5.3V$		0.3 0.7			0.3 0.7			0.3 0.7		Ω
Reference Voltage Change with Current	$10\mu A \leq I_R \leq 1mA$ $1mA \leq I_R \leq 20mA$		0.2 4	1.0 10		0.2 4	1.0 10		0.2 4	1.0 10	mV mV
Min. Operating Current (Note 4)	$V_{OUT} = V_{REF}$ $V_{OUT} = 5.3V$		6 30	9 45		6 30	9 45		6 30	9 45	μA μA
Wide Band Noise (Note 5)	$10Hz \leq f \leq 10kHz$ $V_{OUT} = V_{REF}$ $V_{OUT} = 5.3V$		50 170			50 170			50 170		μV_{rms} μV_{rms}
Temperature Coeff. (Note 6)				25			50		100	150	ppm/°C
Long Term Stability (Note 5)	$T_A = 25^\circ C \pm 1^\circ C$ $T = 1000 Hr$		20			20			20		ppm

ELECTRICAL CHARACTERISTICS

Electrical Characteristics at $I_R = 100 \mu A$, and $T_A = +25^\circ C$ unless otherwise specified.

Parameter	Conditions	AMS285A			AMS285B			AMS285C			Units
		Min	Typ	Max	Min	Typ	Max	Min	Typ	Max	
Reference Voltage	$I_R = 100 \mu A$	1.228	1.240	1.252	1.215	1.240	1.265	1.215	1.240	1.265	V
Dynamic Output Impedance	$I_{AC} = 0.1I_R$, $f = 20Hz$ $V_{OUT} = V_{REF}$ $V_{OUT} = 5.3V$		0.3 0.7			0.3 0.7			0.3 0.7		Ω
Reference Voltage Change with Current	$10\mu A \leq I_R \leq 1mA$ $1mA \leq I_R \leq 20mA$		0.2 4	1.0 10		0.2 4	1.0 10		0.2 4	1.0 10	mV mV
Min. Operating Current (Note 4)	$V_{OUT} = V_{REF}$ $V_{OUT} = 5.3V$		6 30	9 45		6 30	9 45		6 30	9 45	μA μA
Wide Band Noise (Note 5)	$10Hz \leq f \leq 10kHz$ $V_{OUT} = V_{REF}$ $V_{OUT} = 5.3V$		50 170			50 170			50 170		μV_{rms} μV_{rms}
Temperature Coeff. (Note 6)				25			50		100	150	ppm/°C
Long Term Stability (Note 5)	$T_A = 25^\circ C \pm 1^\circ C$ $T = 1000 Hr$		20			20			20		ppm

Note 1: Absolute Maximum Ratings indicate limits beyond which damage to the device may occur. Operating Ratings indicate conditions for which the device is intended to be functional, but do not guarantee specific performance limits. For guaranteed specifications and test conditions, see the Electrical Characteristics. The guaranteed specifications apply only for the test conditions listed.

Note 2: For elevated temperature operation, T_j max is:

AMS285 +125°C
AMS385 +100°C

Thermal Resistance	TO-92	SO-8	SOT-89
θ_{JA} (junction to ambient)	170°C/W (0.125" leads)	165°C/W	160°C/W

Note 3: Parameters identified with **boldface type** apply at temperature extremes. All other numbers apply at $T_A = T_J = 25^\circ\text{C}$.

Note 4: Guaranteed and 100% production tested.

Note 5: Guaranteed but not 100% production tested. These limits are not used to calculate average outgoing quality levels.

Note 6: The average temperature coefficient is defined as the maximum deviation of reference voltage at all measured temperatures between the operating T_{MAX} and T_{MIN} , divided by $T_{MAX} - T_{MIN}$. The measured temperatures are 0°C, 25°C, 70°C and 85°C.

PIN CONNECTIONS

TO-92
Plastic Package (N)

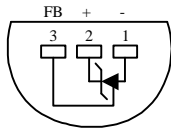

Bottom View

8L SOIC
SO Package (S)

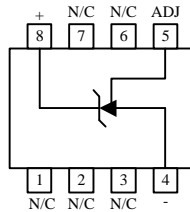

Top View

SOT-89
(L)

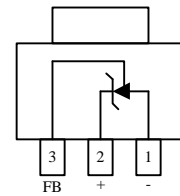

Top View

TYPICAL APPLICATIONS

1.2V Reference

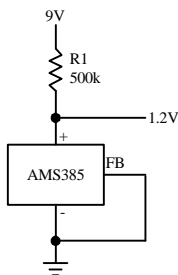

5.0V Reference

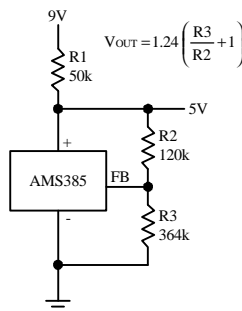

Precision 10V Reference

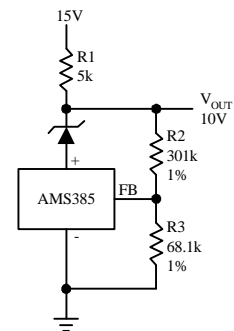

TYPICAL APPLICATIONS (Continued)

Low AC Noise Reference

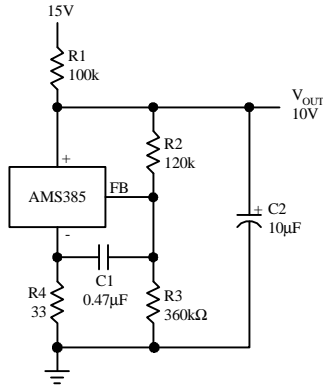

Current Source

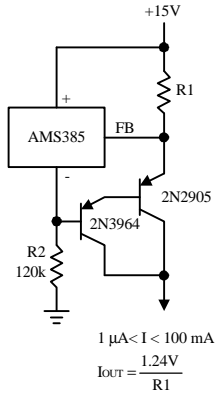

25V Low Current Shunt Regulator

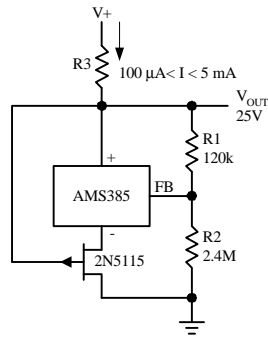

200mA Shunt Regulator

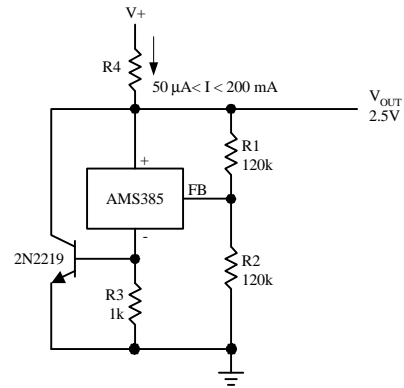

Voltage Level Detector

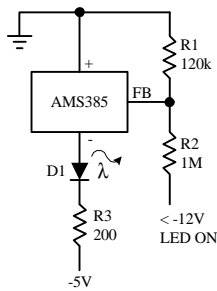

Voltage Level Detector

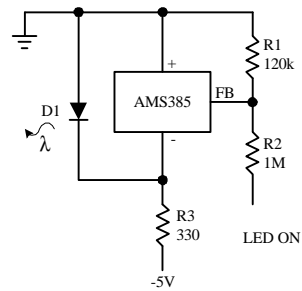

TYPICAL APPLICATIONS (Continued)

Bidirectional Clamp
± 2.4V

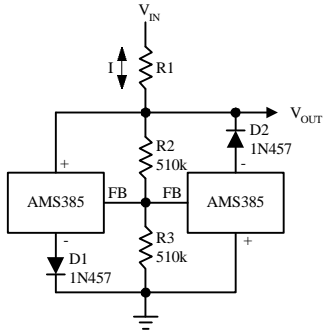

Bidirectional Adjustable Clamp
± 1.8V to ± 2.4V

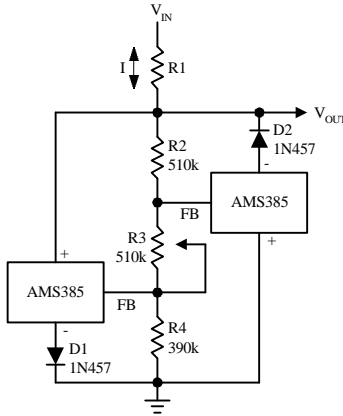

Bidirectional Adjustable Clamp
± 2.4V to ± 6V

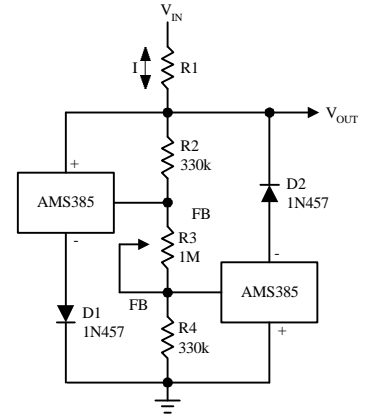

TYPICAL PERFORMANCE CHARACTERISTICS

AMS285 Typical Temperature Coefficient

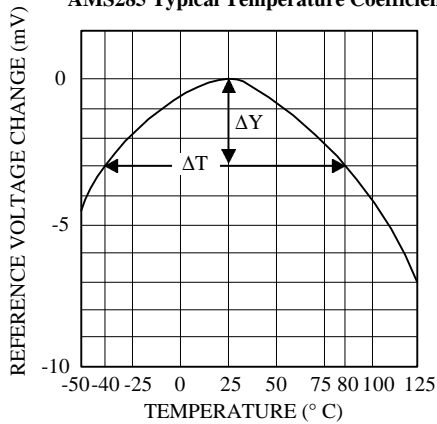

AMS385 Typical Temperature Coefficient

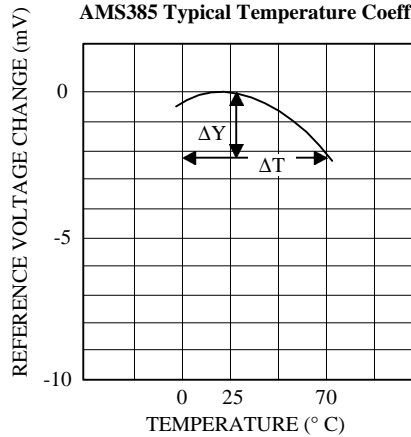

$$\text{TEMPCO} = \frac{\Delta Y}{\Delta T}$$

TYPICAL PERFORMANCE CHARACTERISTICS (Continued)

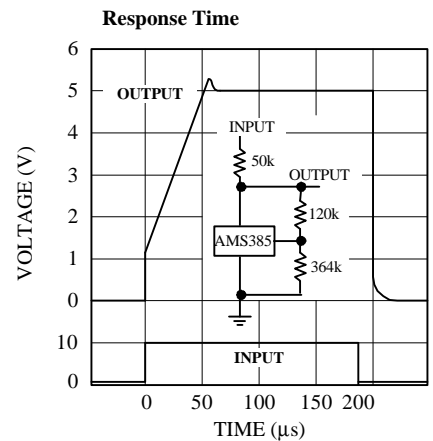
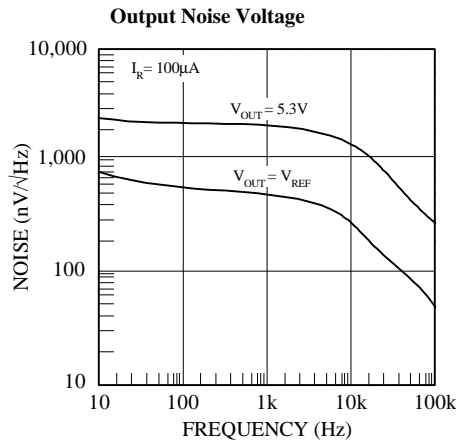
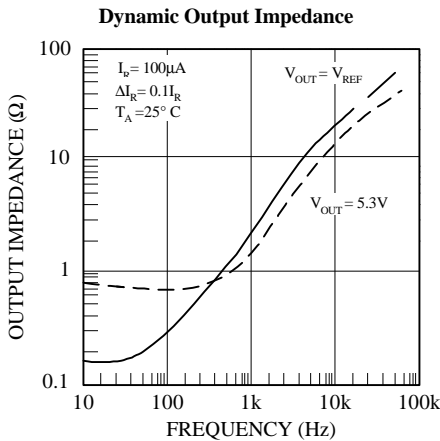
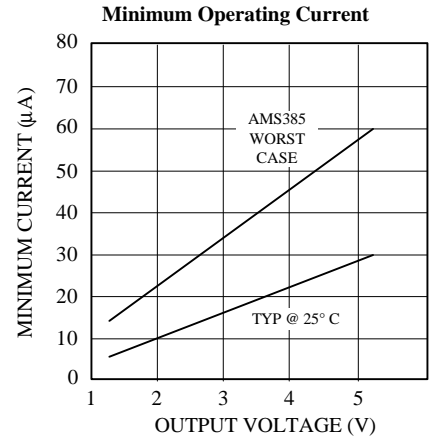
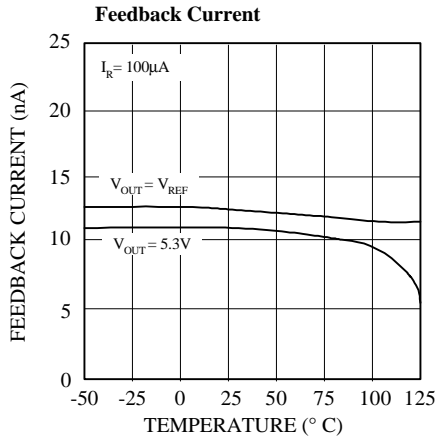
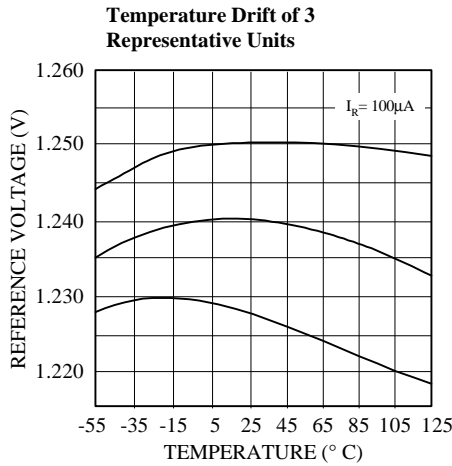
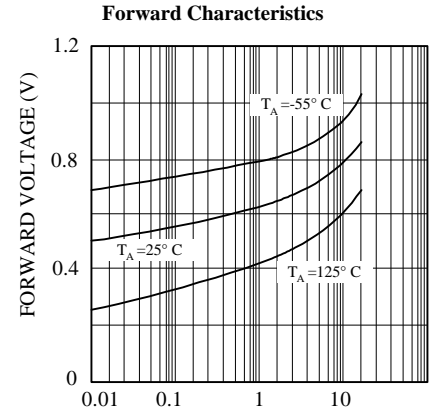
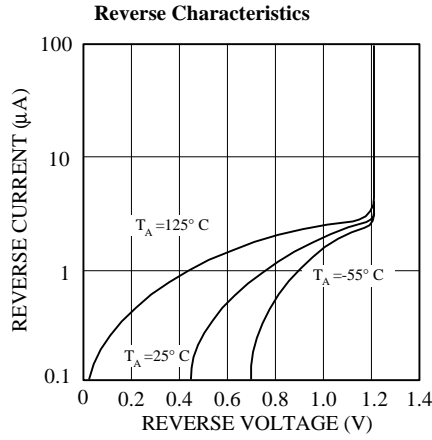
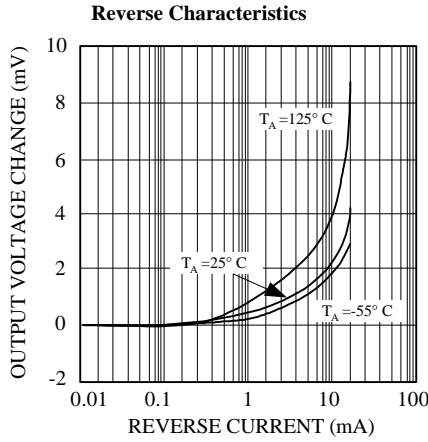

PACKAGE DIMENSIONS inches (millimeters) unless otherwise noted (Continued).

SOT-89 PLASTIC PACKAGE (L)

