

**FEATURES**

- Adjustable from 1.24V to 5.30V
- Operating Current 10µA to 20mA
- 1% and 2% Initial Tolerance
- 1Ω Dynamic Impedance
- Low Temperature Coefficient
- 1.2V Device and 2.5V Device also available

**APPLICATIONS**

- Battery Powered Systems
- Instrumentation
- A/D, D/A Converters
- Temperature measurement
- Current sources
- Notebook/Personal Computer
- Monitors/ VCR/ TV
- Pagers

**GENERAL DESCRIPTION**

The AMS3100 are two-terminal micropower band-gap voltage reference that feature a very low dynamic impedance and good temperature coefficient, operating from 1.24V to 5.3V and over a 10µA to 20mA current range. AMS3100 is trimmed at wafer test level to optimize the temperature coefficient and tight output voltage tolerance. The advanced process technology used, makes the AMS3100 exceptionally tolerant of capacitive loading, making it easy to use in almost any reference application. The wide dynamic operating range allows its use with widely varying supplies with excellent regulation. The extremely low power drain, makes these reference diodes useful for micropower circuitry. These voltage references can be used to make portable meters, regulators or general purpose analog circuitry with battery life approaching shelf life. Further more, the wide operating current allows it to replace older references with a tight tolerance part. Pin to pin compatible with other standard industry references, the AMS3100 offers the advantage of long term stability at low cost.

The AMS3100 is operating over a -40°C to 85°C temperature range and is available in the space saving SOT-23 package.

**ORDERING INFORMATION:**

TOL.	PACKAGE TYPE	OPERATING TEMPERATURE RANGE
	SOT-23	
±12mV	AMS3100AM	-40°C to 85°C
±25mV	AMS3100BM	-40°C to 85°C
±25mV	AMS3100CM	-40°C to 85°C

**PIN CONNECTIONS**

3L SOT-23  
(M)

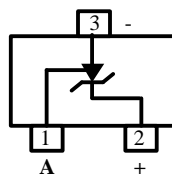

A = Adjust pin.

**Top View**

## ABSOLUTE MAXIMUM RATINGS

Reverse Current	30mA	Lead Temperature	
Forward Current	10mA	Vapor phase (60 sec)	215°C
Operating Temperature Range	-40°C to 85°C	Infrared (15 sec.)	220°C
Storage temperature	-55°C to +150°C	Thermal Resistance ( $\theta_{JA}$ )	410°C/W

## ELECTRICAL CHARACTERISTICS

Electrical Characteristics at  $I_R = 100 \mu A$ , and  $T_A = +25^\circ C$  unless otherwise specified.

Parameter	Conditions	AMS3100A			AMS3100B			AMS3100C			Units
		Min	Typ	Max	Min	Typ	Max	Min	Typ	Max	
Reference Voltage	$I_R = 100 \mu A$	1.238	1.250	1.262	1.225	1.250	1.275	1.225	1.250	1.275	V
Dynamic Output Impedance	$I_{AC} = 0.1 I_R$ , $f = 20 Hz$ $V_{OUT} = V_{REF}$ $V_{OUT} = 5.3 V$		0.3 0.7			0.3 0.7			0.3 0.7		$\Omega$
Reference Voltage Change with Current	$10 \mu A \leq I_R \leq 1 mA$ $1 mA \leq I_R \leq 20 mA$		0.2 4	1.0 10		0.2 4	1.0 10		0.2 4	1.0 10	mV mV
Min. Operating Current (Note 3)	$V_{OUT} = V_{REF}$ $V_{OUT} = 5.3 V$		6 30	9 45		6 30	9 45		6 30	9 45	$\mu A$ $\mu A$
Wide Band Noise (Note 4)	$10 Hz \leq f \leq 10 kHz$ $V_{OUT} = V_{REF}$ $V_{OUT} = 5.3 V$		50 170			50 170			50 170		$\mu V_{rms}$ $\mu V_{rms}$
Temperature Coeff. (Note 5)				25			50		100	150	ppm/°C
Long Term Stability (Note 4)	$T_A = 25^\circ C \pm 1^\circ C$ $T = 1000 Hr$		20			20			20		ppm

**Note 1:** Absolute Maximum Ratings indicate limits beyond which damage to the device may occur. Operating Ratings indicate conditions for which the device is intended to be functional, but do not guarantee specific performance limits. For guaranteed specifications and test conditions, see the Electrical Characteristics. The guaranteed specifications apply only for the test conditions listed.

**Note 2:** Parameters identified with **boldface type** apply at temperature extremes. All other numbers apply at  $T_A = T_J = 25^\circ C$ .

**Note 3:** Guaranteed and 100% production tested

**Note 4:** Guaranteed but not 100% production tested. These limits are not used to calculate average outgoing quality levels.

**Note 5:** The average temperature coefficient is defined as the maximum deviation of reference voltage at all measured temperatures between the operating  $T_{MAX}$  and  $T_{MIN}$ , divided by  $T_{MAX} - T_{MIN}$ . The measured temperatures are  $-40^\circ C$ ,  $25^\circ C$  and  $85^\circ C$ .

## TYPICAL APPLICATIONS

1.2V Reference

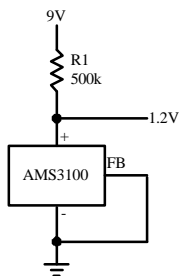

5.0V Reference

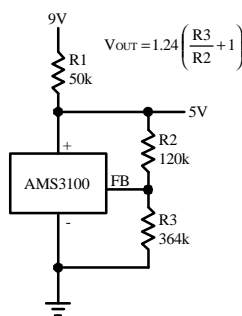

Precision 10V Reference

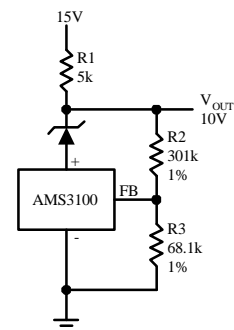

## TYPICAL APPLICATIONS (Continued)

**Low AC Noise Reference**

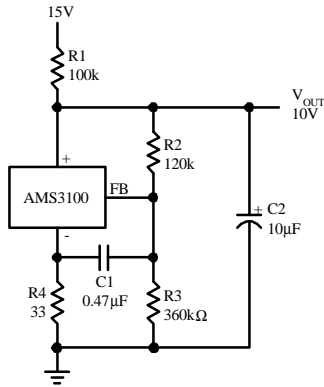

**Current Source**

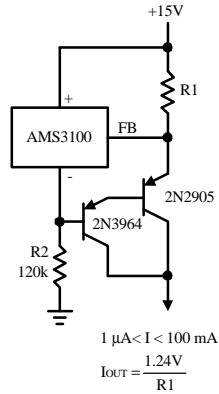

**25V Low Current Shunt Regulator**

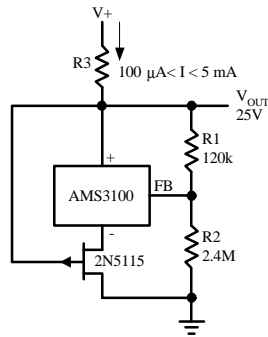

**200mA Shunt Regulator**

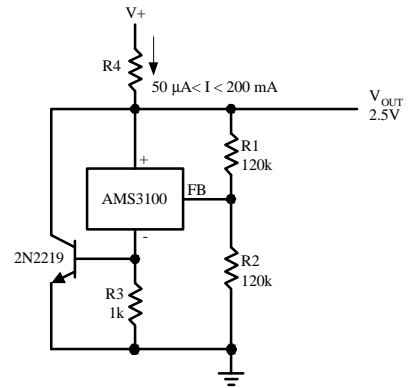

**Voltage Level Detector**

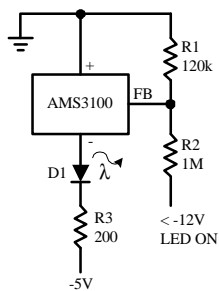

**Voltage Level Detector**

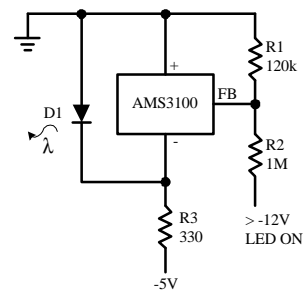

## TYPICAL APPLICATIONS (Continued)

**Bidirectional Clamp**  
± 2.4V

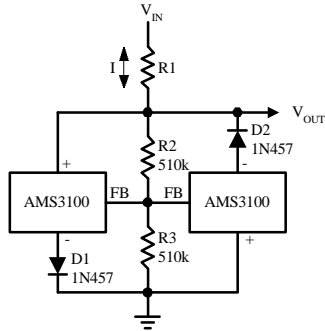

**Bidirectional Adjustable Clamp**  
± 1.8V to ± 2.4V

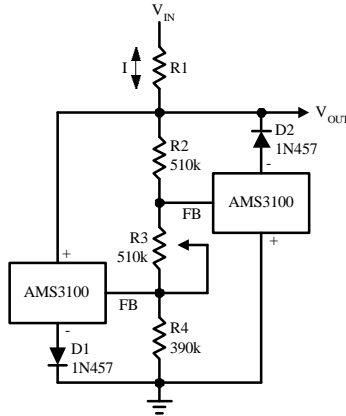

**Bidirectional Adjustable Clamp**  
± 2.4V to ± 6V

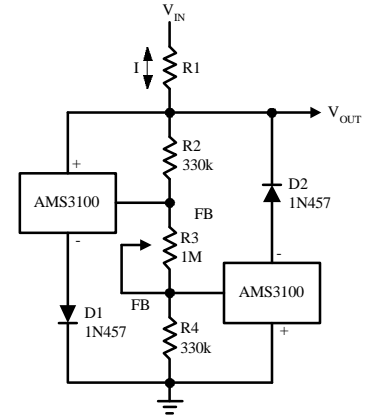

## TYPICAL PERFORMANCE CHARACTERISTICS

AMS3100 Typical Temperature Coefficient

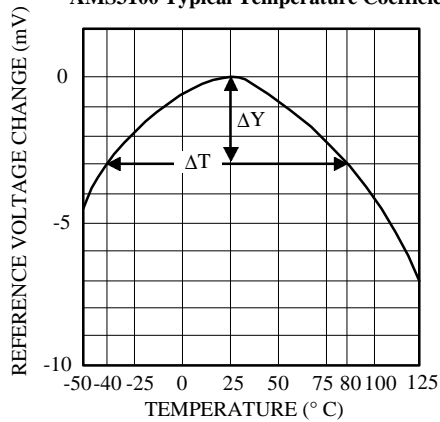

$$\text{TEMPCO} = \frac{\Delta Y}{\Delta T}$$

## TYPICAL PERFORMANCE CHARACTERISTICS (Continued)

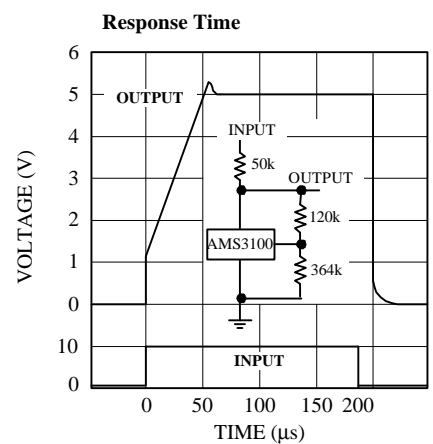
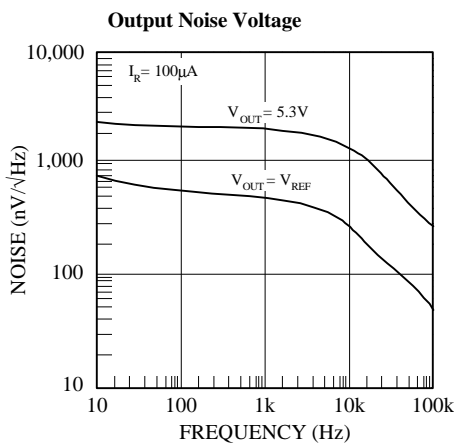
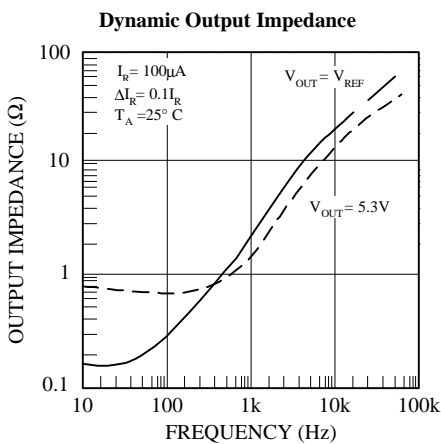
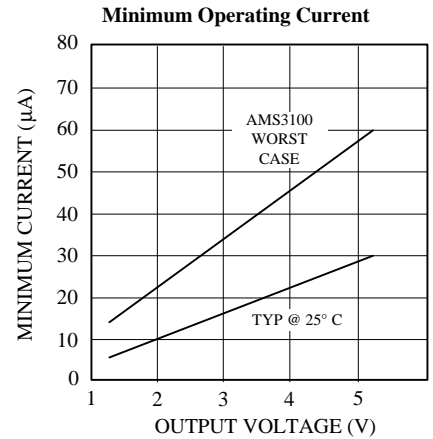
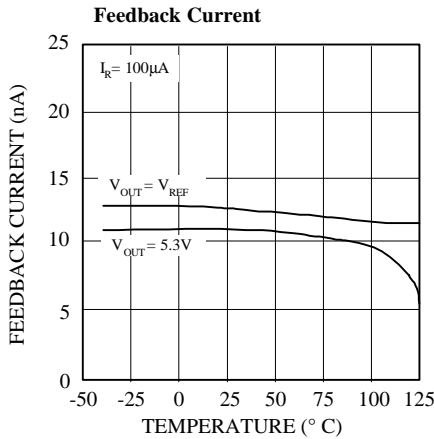
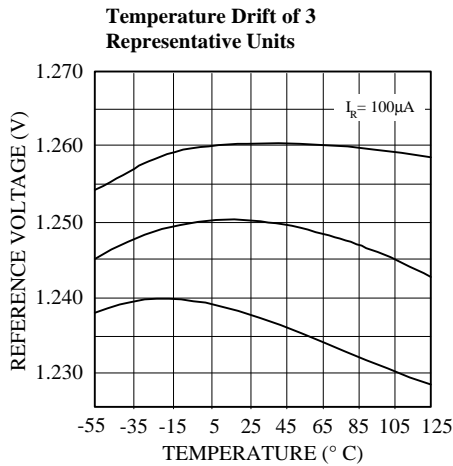
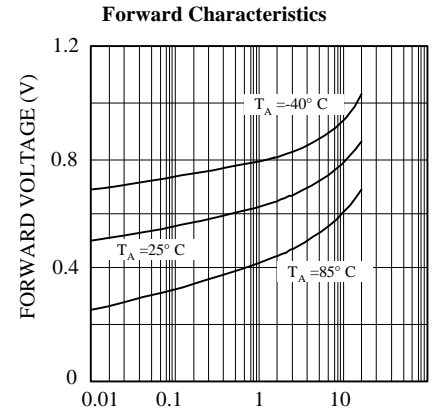
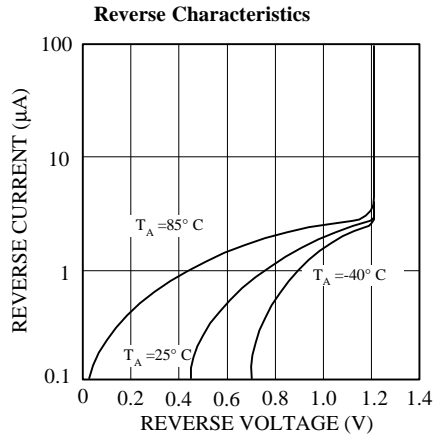
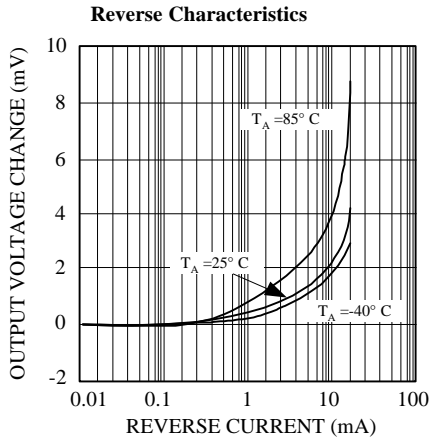

PACKAGE DIMENSIONS inches (millimeters) unless otherwise noted.

## 3 LEAD SOT-23 PLASTIC PACKAGE (M)

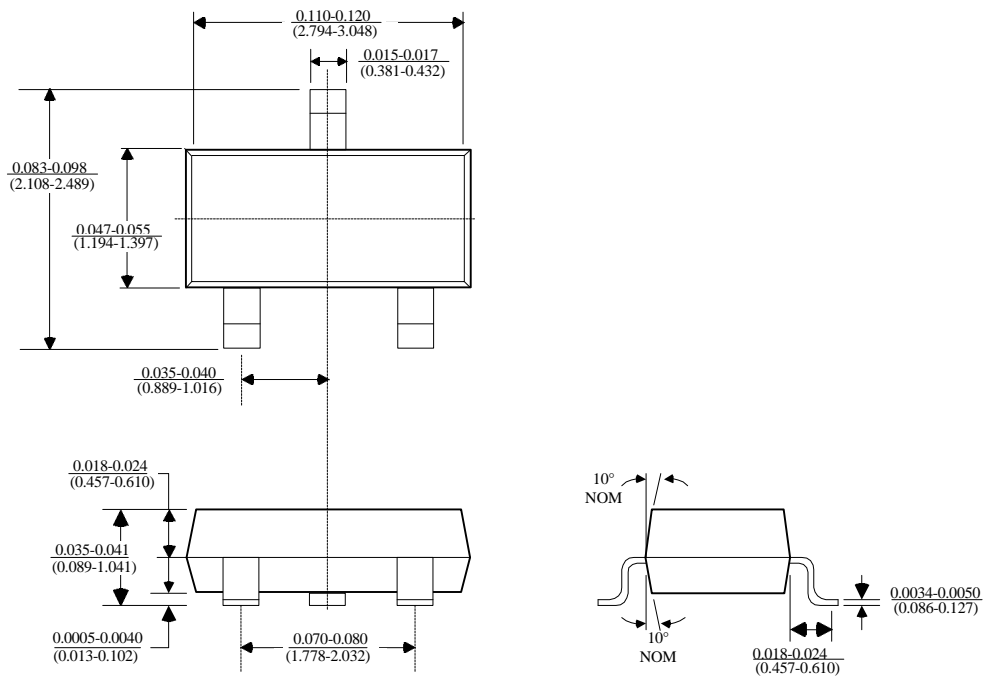

(SOT-23) AMS DRW# 051991