

FEATURES

- ± 12 mV ($\pm 0.5\%$) max. initial tolerance (A grade)
- Operating Current 20 μ A to 20mA
- Low Voltage Reference 2.50V
- Max. 0.5 Ω Dynamic Impedance (A grade)
- Low Temperature Coefficient
- SOT-23 Package Available
- Low cost

APPLICATIONS

- Battery Powered Systems
- Instrumentation
- A/D, D/A Converters
- Temperature measurement
- Current sources
- Notebook/Personal Computer
- Monitors/ VCR/ TV
- Pagers

GENERAL DESCRIPTION

The AMS3100-2.5 are two-terminal micropower band-gap voltage reference that feature a very low dynamic impedance and good temperature coefficient, operating over a 20 μ A to 20mA current range. AMS3100-2.5 is trimmed at wafer test level to optimize the temperature coefficient and tight output voltage tolerance. The advanced process technology used, makes the AMS3100-2.5 exceptionally tolerant of capacitive loading, making it easy to use in almost any reference application. The wide dynamic operating range allows its use with widely varying supplies with excellent regulation. The extremely low power drain, makes these reference diodes useful for micropower circuitry. These voltage references can be used to make portable meters, regulators or general purpose analog circuitry with battery life approaching shelf life. Further more, the wide operating current allows it to replace older references with a tight tolerance part. Pin to pin compatible with other standard industry references, the AMS3100-2.5 offers the advantage of long term stability at low cost.

The AMS3100-2.5 is operating over a -40°C to 85°C temperature range and is available in the space saving SOT-23 package.

ORDERING INFORMATION:

TOL.	PACKAGE TYPE	OPERATING TEMPERATURE RANGE
	SOT-23	
± 12 mV	AMS3100-2.5AM	-40°C to 85°C
± 25 mV	AMS3100-2.5BM	-40°C to 85°C
± 50 mV	AMS3100-2.5CM	-40°C to 85°C

PIN CONNECTIONS

3L SOT-23
(M)

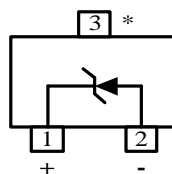

Top View

*This pin must be left floating or connected to pin 2

AMS3100-2.5

ABSOLUTE MAXIMUM RATINGS

Reverse Current	30mA	Lead Temperature	
Forward Current	10mA	Vapor phase (60 sec)	215°C
Operating Temperature Range	-40°C to 85°C	Infrared (15 sec.)	220°C
Storage temperature	-55°C to +150°C	Thermal Resistance (θ_{JA})	410°C/W

ELECTRICAL CHARACTERISTICS

Electrical Characteristics at $I_R = 100 \mu A$, and $T_A = +25^\circ C$ unless otherwise specified.

Parameter	Conditions	AMS3100A-2.5			AMS3100B-2.5			AMS3100C-2.5			Units
		Min	Typ	Max	Min	Typ	Max	Min	Typ	Max	
Reverse Breakdown Voltage (Note 3)	$I_R - 100 \mu A$	2.488	2.500	2.512	2.475	2.500	2.525	2.450	2.500	2.550	V
Reverse Dynamic Impedance (Note 3)	$I_R - 100 \mu A, f = 20Hz$		0.2	0.60		1			1		Ω
Reverse Breakdown Voltage Change with current (Note 3)	$10\mu A \leq I_R \leq 1mA$ $1mA \leq I_R \leq 20mA$		1.0 10				1.0 10			2.0 20	mV
Min. Operating Current (Note 3)			12 20 25			13	20 30		13	20 30	μA μA
Wide Band Noise (Note 4)	$I_R - 100 \mu A,$ $10Hz \leq f \leq 10kHz$		120			120			120		μV
Temperature Coeff. (Note 5)			25			50			100	150	ppm/°C
Long Term Stability (Note 4)	$T_A = 25^\circ C \pm 1^\circ C$ $T = 1000 Hr$		20			20			20		ppm

Note 1: Absolute Maximum Ratings indicate limits beyond which damage to the device may occur. Operating Ratings indicate conditions for which the device is intended to be functional, but do not guarantee specific performance limits. For guaranteed specifications and test conditions, see the Electrical Characteristics. The guaranteed specifications apply only for the test conditions listed.

Note 2: Parameters identified with **boldface type** apply at temperature extremes. All other numbers apply at $T_A = T_J = 25^\circ C$.

Note 3: Guaranteed and 100% production tested

Note 4: Guaranteed but not 100% production tested. These limits are not used to calculate average outgoing quality levels.

Note 5: The average temperature coefficient is defined as the maximum deviation of reference voltage at all measured temperatures between the operating T_{MAX} and T_{MIN} , divided by $T_{MAX} - T_{MIN}$. The measured temperatures are $-40^\circ C$, $25^\circ C$ and $85^\circ C$.

TYPICAL APPLICATIONS

Wide Input Range Reference

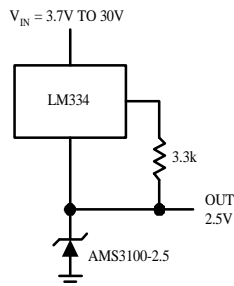

Micropower Reference from 9V Battery

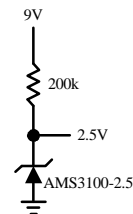

TYPICAL APPLICATIONS (Continued)

0°C - 100°C Thermometer

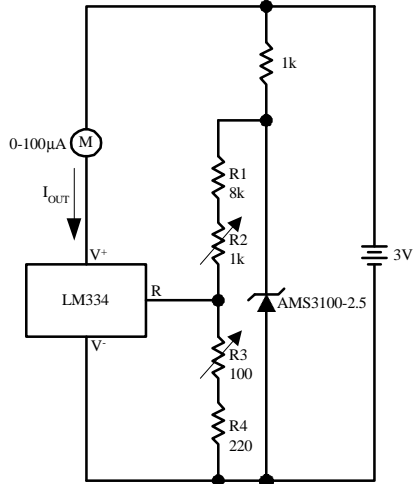

Calibration

1. Short AMS3100-2.5, adjust R3 for $I_{OUT} = \text{temp}$ at $1\mu\text{A}/^\circ\text{K}$
2. Remove short, adjust R2 for correct reading in $^\circ\text{C}$

0°C - 100°C Thermometer

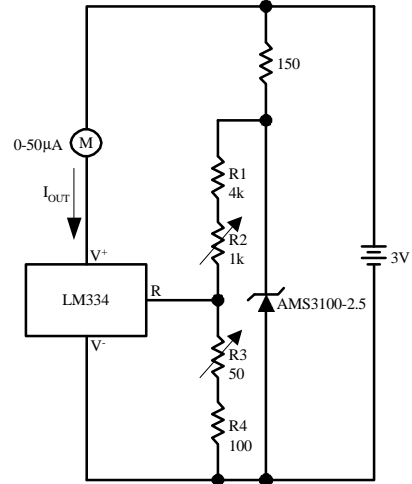

Calibration

1. Short AMS3100-2.5, adjust R3 for $I_{OUT} = \text{temp}$ at $1.8\mu\text{A}/^\circ\text{K}$
2. Remove short, adjust R2 for correct reading in $^\circ\text{F}$

Micropower* 5V Regulator

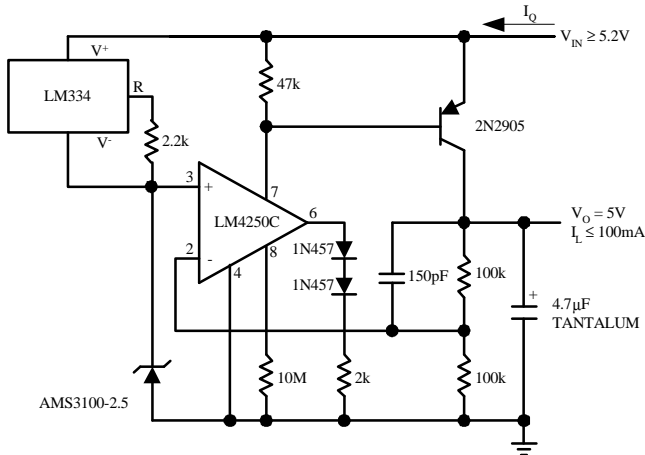

* $I_Q \cong 40\mu\text{A}$

Micropower* 10V Reference

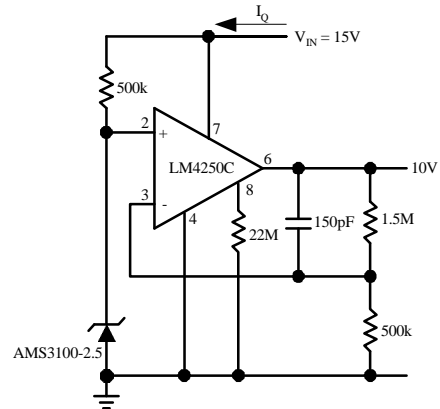

* $I_Q \cong 20\mu\text{A}$ standby current

TYPICAL APPLICATIONS (Continued)

Micropower Thermocouple Cold Junction Compensator

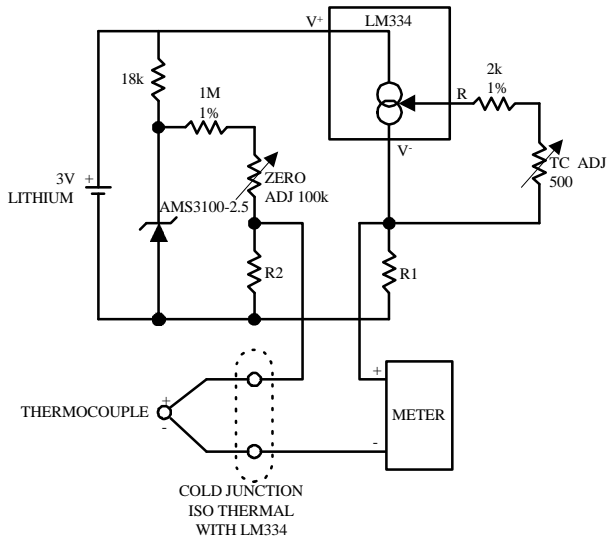

Adjustment Procedure

1. Adjust TC ADJ pot until voltage across R1 equals Kelvin temperature multiplied by the thermocouple Seebeck coefficient.
2. Adjust ZERO ADJ pot until voltage across R2 equals the thermocouple Seebeck coefficient multiplied by 273.2.

Thermocouple Type	Seebeck Coefficient (mV/°C)	R1 (Ω)	R2 (Ω)	Voltage Across R1 @ 25°C (mV)	Voltage Across R2 (mV)
J	52.3	523	1.24k	15.60	14.32
T	42.8	432	1k	12.77	11.78
K	40.8	412	953Ω	12.17	11.17
S	6.4	63.4	150Ω	1.908	1.766

Typical supply current 50μA

Precision 1μA to 1mA Current Sources

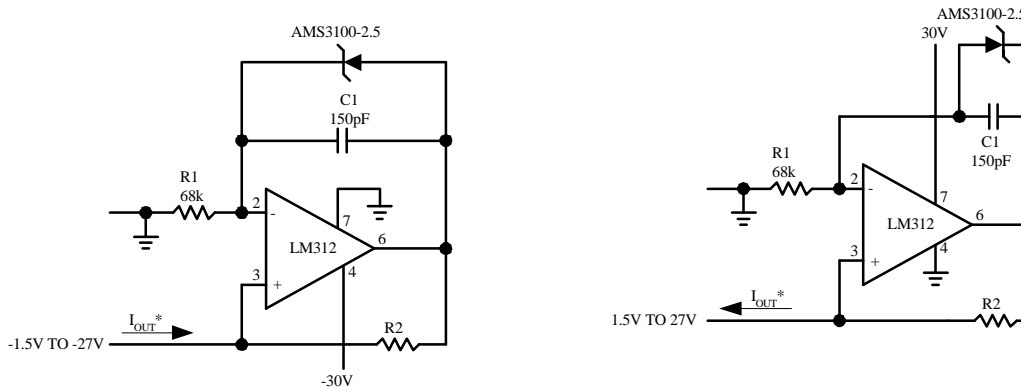

$$*I_{OUT} = 2.5V/R2$$

TYPICAL PERFORMANCE CHARACTERISTICS

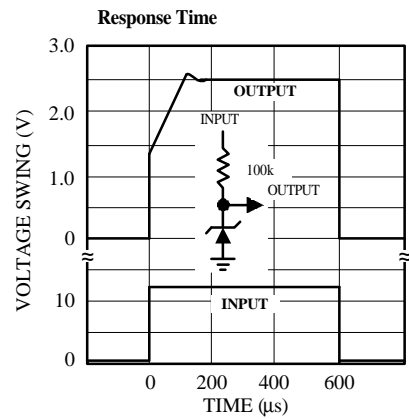
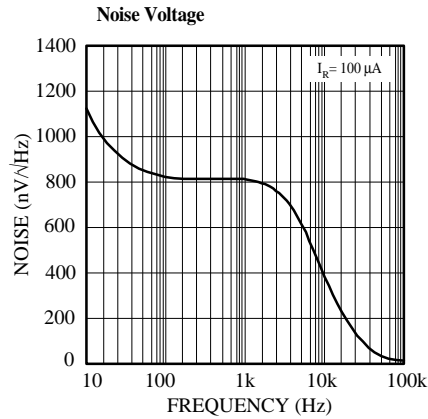
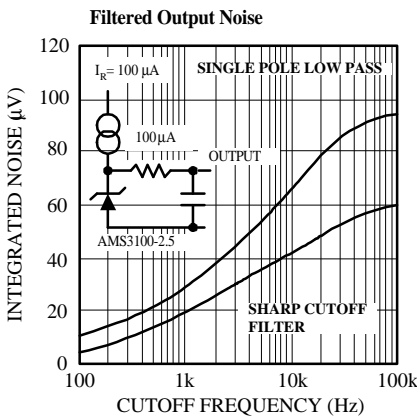
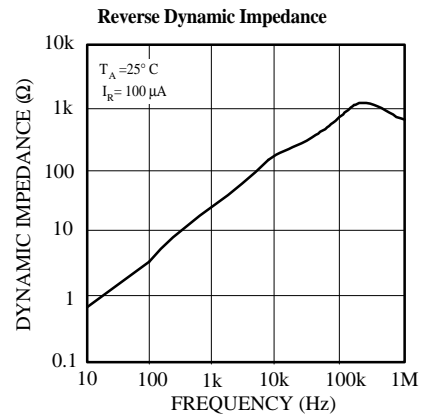
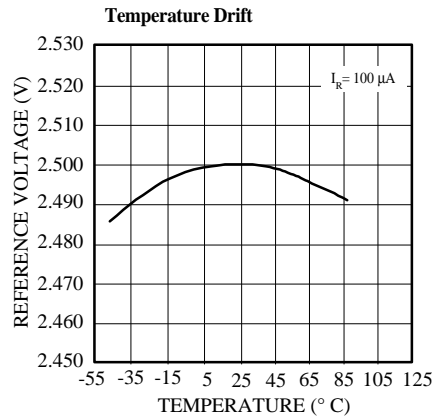
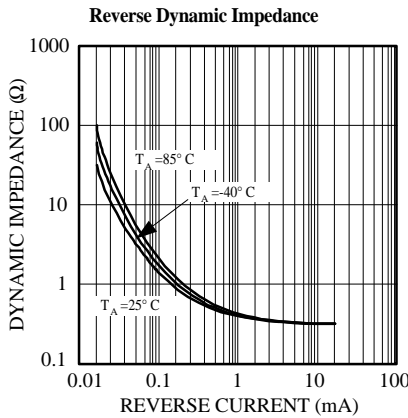
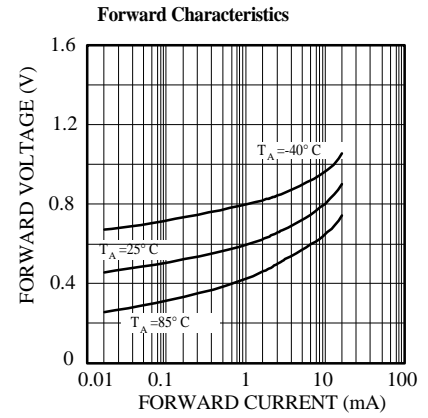
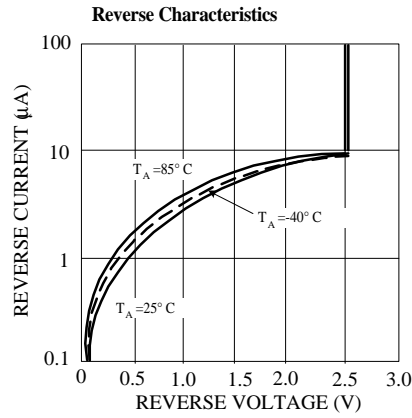
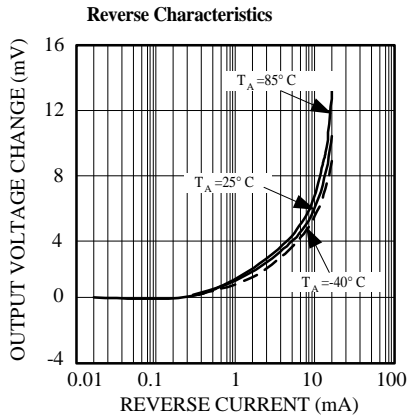

PACKAGE DIMENSIONS inches (millimeters) unless otherwise noted.

3 LEAD SOT-23 PLASTIC PACKAGE (M)

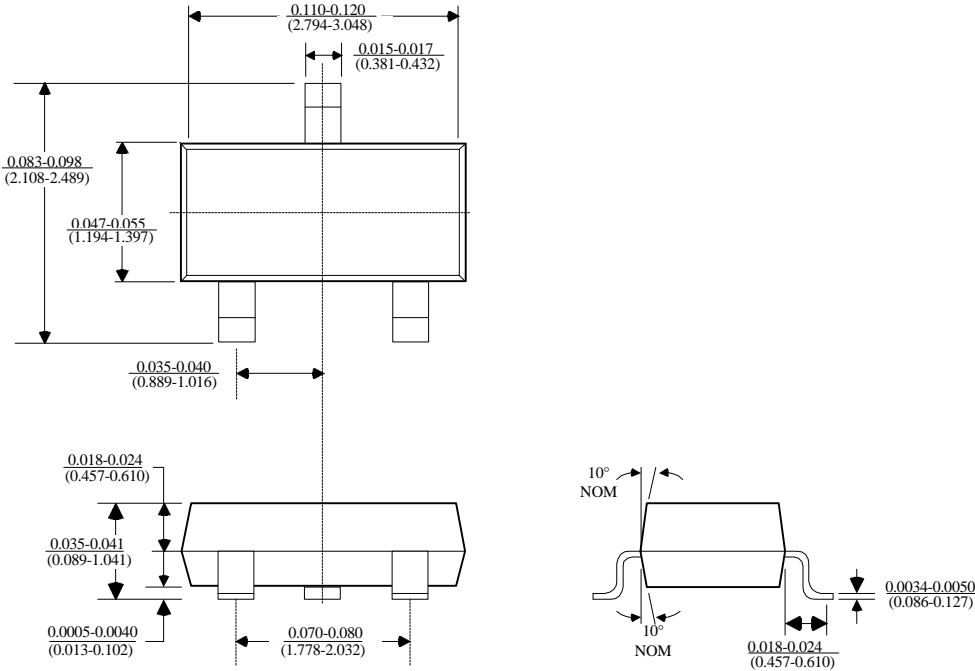

(SOT-23) AMS DRW# 051991